

- 1 Sensor ASIC mounted on PCB
- 2 Tag in vacuum panels

## SENSOR TRANSPONDER FOR PRESSURE AND TEMPERATURE

### Fraunhofer Institute for Microelectronic Circuits and Systems IMS

Finkenstr. 61  
D - 47057 Duisburg  
Telefon +49 203 37 83-0  
Fax +49 203 37 83-266  
[www.ims.fraunhofer.de](http://www.ims.fraunhofer.de)

contact  
Michael Bollerott  
Telefon +49 203 37 83-227  
[vertrieb@ims.fraunhofer.de](mailto:vertrieb@ims.fraunhofer.de)



The sensor transponder has been developed for the remote measurement of absolute pressure and temperature in the fields of industrial electronics and medical implants. The device is fabricated in one monolithic CMOS chip which increases reliability and reduces fabrication costs. A cross section of the CMOS process used for fabrication is shown in figure 4.

### Pressure Sensor

The integrated capacitive pressure sensor consists of an array of single circular pressure sensitive elements connected in parallel. The capacitor is formed by a fixed electrode in the substrate and a deflectable membrane of polycrystalline silicon mounted on top. The cavity under the membrane is obtained by anisotropic etching and a subsequent vacuum sealing.

### Sensor Readout Electronics

The on-chip sensor readout electronic consists of a special A/D converter and a selection circuitry which switches between the pressure sensor and temperature sensor for readout. A typical pressure curve is shown in figure 3 and a temperature curve in figure 5.

### Transponder System

Fig. 6 gives an overview over all necessary components of the system. A measurement is initiated by the remote reader unit, while the RF field of the reader activates the sensor. The sensor electronic takes a measurement and transmits a data package to the reader unit. For this transmission the method of absorption modulation is applied, which frequently is used in transponder systems.

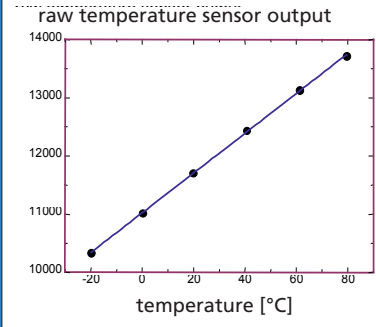
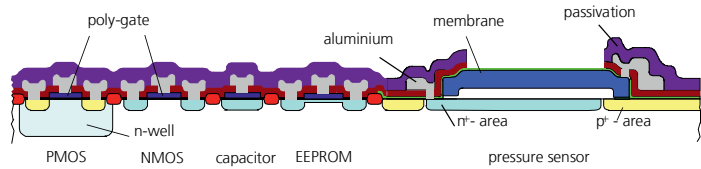
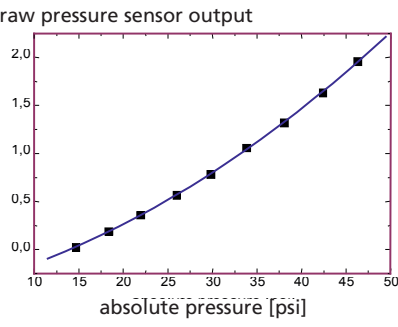

The transmitted data package includes the sensor readout data, calibration data, a unique identification number and a checksum for data validation. The reader unit derives the measured pressure and temperature from the received data by a fixed formula. Depending on the size of the reader and the sensor antennas, an operating distance of up to 1m in free space can be reached. A typical range value is up to 50cm for stationary reader units and up to 25cm for hand held reader units. As external

component for the ASIC only an antenna, based on a coil with resonance capacitor and an additional capacitor for smoothing the operating voltage (VCC), is necessary. Therefore costs are reduced and the reliability of the system (Fig.6) is increased. The sensor is calibrated automatically, storing the calibration coefficients for pressure and temperature in the on-chip EEPROM.

**Applications**

- Due to the low cost, small size and the high performance the system is ideally suited for many applications like:
- Remote blood pressure and temperature measurement
  - Remote pressure and temperature measurement in machines and rotating parts
  - Chemical process control
  - Control of vacuum panels (Fig. 1,2 and Fig. 7)

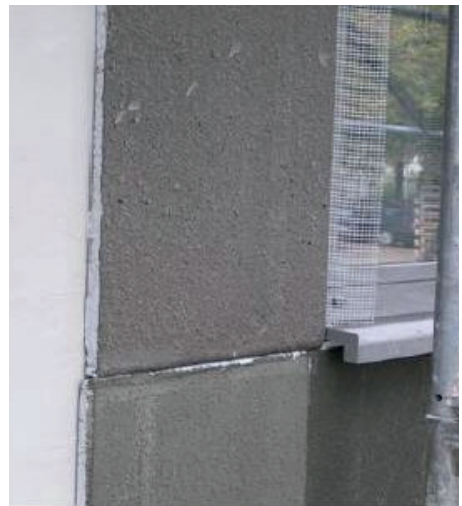
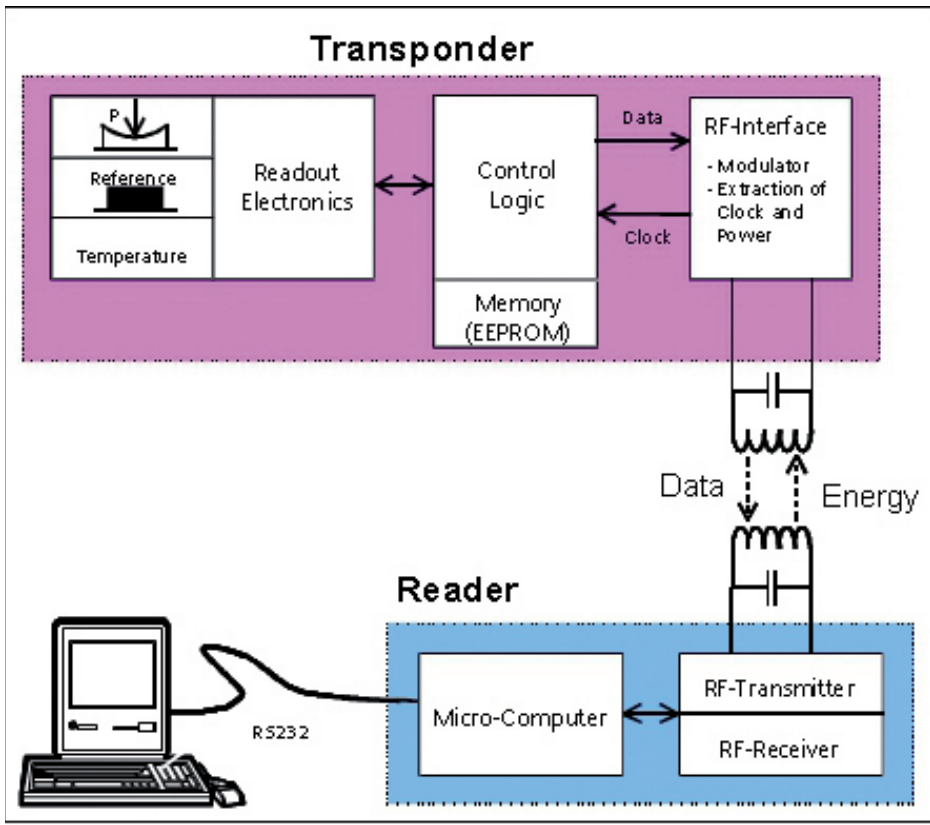

- 3 Typical sensor curve for the pressure sensor
- 4 Cross section of the integrated pressure sensor process
- 5 Typical sensor curve for the temperature sensor
- 6 Blockdiagramm of the sensor system
- 7 Mounted vacuum panels