

High Resolution Digital PWM Controller

Features

- Fully programmable power controller or stand-alone PWM (Pulse Width Modulation) generator
- High resolution PWM with 200 ps pulse-width resolution
- Supports switching frequencies from 150 kHz up to 8 MHz
- Dead time configurable from 5 ns up to 5000 ns (cycle-to-cycle)
- RISC-V core (AIRISC-POWER) with a processing power of 250 CoreMark
- DSP and **AI acceleration for TFlite, PyTorch, our framework AlFES** and others
- »ASIL-D ready« RISC-V core for ISO 26262 compliance
- Six-channel, 12-bit analog frontend for current and voltage feedbacks
- Fast trip control monitor with configurable thresholds for each input, providing enhanced safety and reliability
- Protection against over- and undervoltage, as well as over-temperature faults
- Operation modes:
 - External PWM control via SPI (Serial Peripheral Interface)
 - Internal PWM control by AIRISC-POWER
- QFN64 package

Applications

This programmable controller IC with integrated single-channel high resolution PWM is developed for optimized control of next-generation gallium nitride and silicon carbide power devices with high switching frequencies, such as in:

- Lighting
- PV inverters
- E-mobility (powertrain and charging)
- Power factor correction
- Datacenter Point-of-Load converters

Turn Page
for the Functional Block Diagram



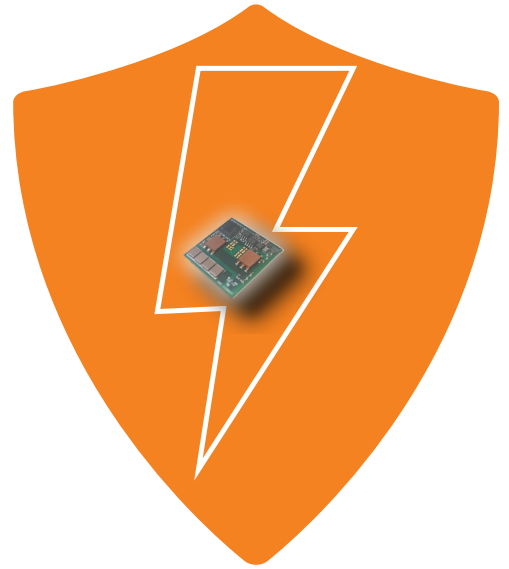

Functional Block Diagram

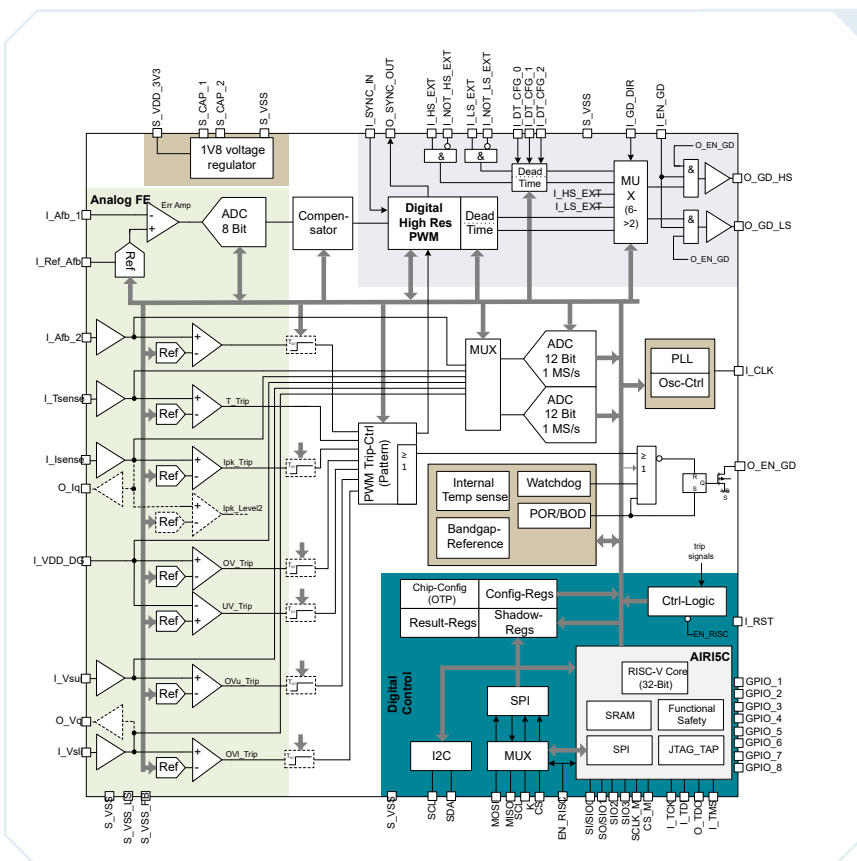

Contact and Further Information

Business Unit Industry
sales@ims.fraunhofer.de

Fraunhofer Institute for Microelectronic Circuits and Systems IMS
Finkenstraße 61
47057 Duisburg
www.ims.fraunhofer.de/en.html

